

GENERAL ARRANGEMENT PLAN

4/CONS-0100-01-R4

- LEGEND
- Asphalt Carriageway
 - Asphalt Carriageway (Coloured)
 - Red Asphalt Cycle Track
 - Flag Paved Footway
 - Imprint Paving
 - Feature Paved Footway
 - Asphalt Footway
 - Charcoal Tactile Paving
 - Red Tactile Paving
 - Verge Areas
 - Existing Lighting Column
 - Relocated Lighting Column
 - Natural Stone Boulders
 - Proposed Bench
 - Existing Tree
 - Proposed Tree
 - Scheme Extents

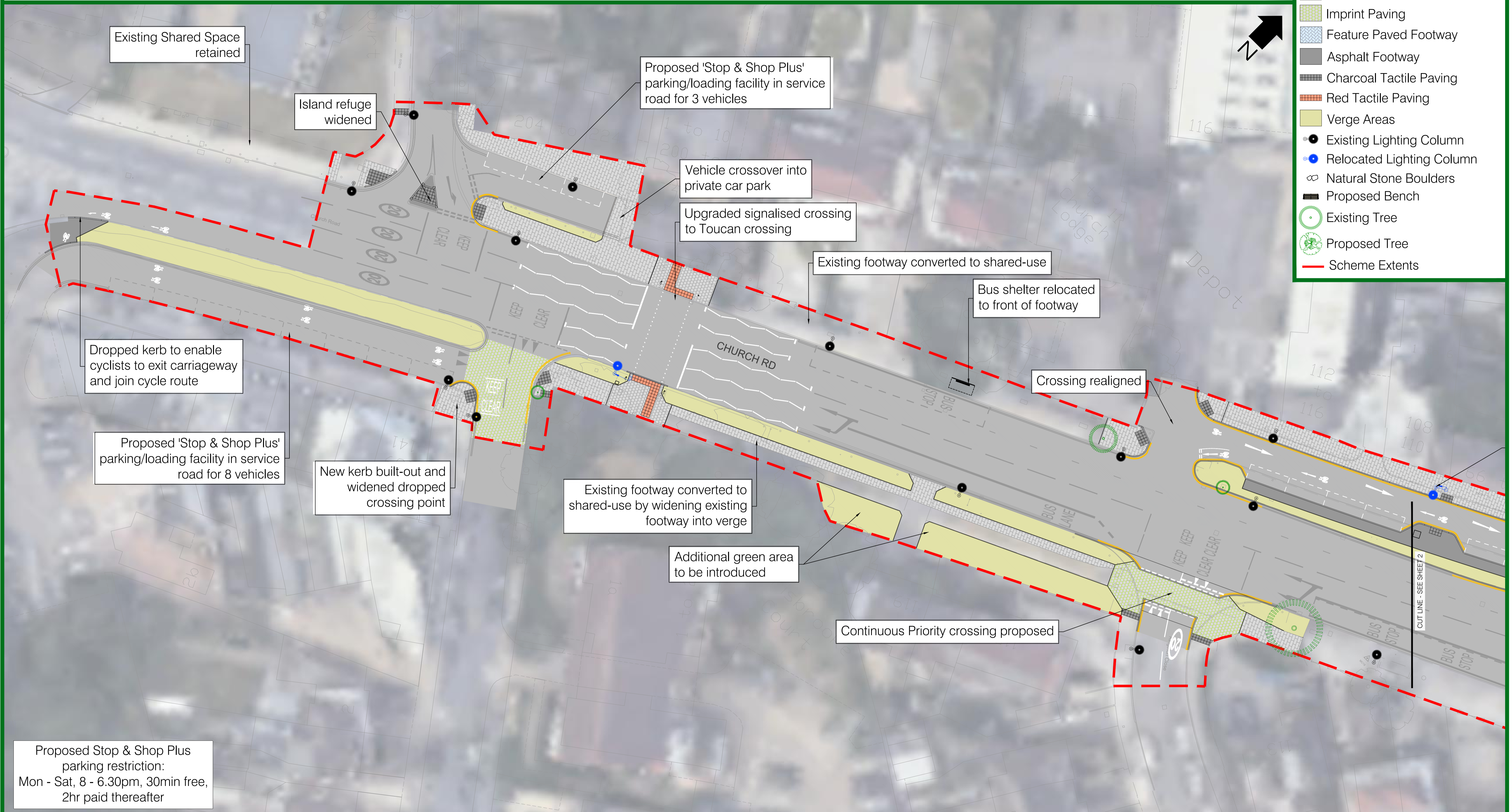

Proposed Stop & Shop Plus parking restriction:
 Mon - Sat, 8 - 6.30pm, 30min free,
 2hr paid thereafter

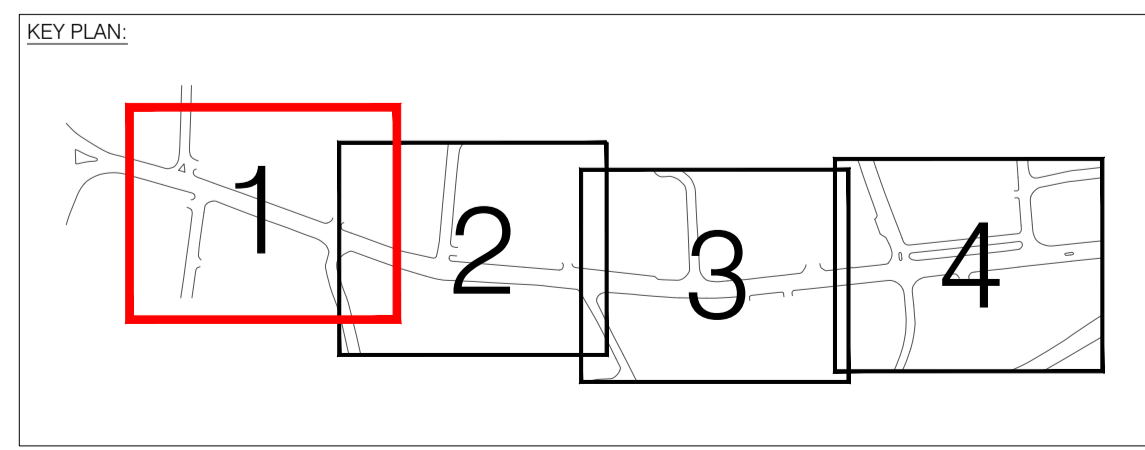

VISIONS FOR NORTHOLT

MANDEVILLE ROAD IMPROVEMENTS

PROJECT CENTRE

www.ealing.gov.uk

GENERAL ARRANGEMENT PLAN

4/CONS-0100-02-R4

- LEGEND
- Asphalt Carriageway
 - Asphalt Carriageway (Coloured)
 - Red Asphalt Cycle Track
 - Flag Paved Footway
 - Imprint Paving
 - Feature Paved Footway
 - Asphalt Footway
 - Charcoal Tactile Paving
 - Red Tactile Paving
 - Verge Areas
 - Existing Lighting Column
 - Relocated Lighting Column
 - Natural Stone Boulders
 - Proposed Bench
 - Existing Tree
 - Proposed Tree
 - Scheme Extents

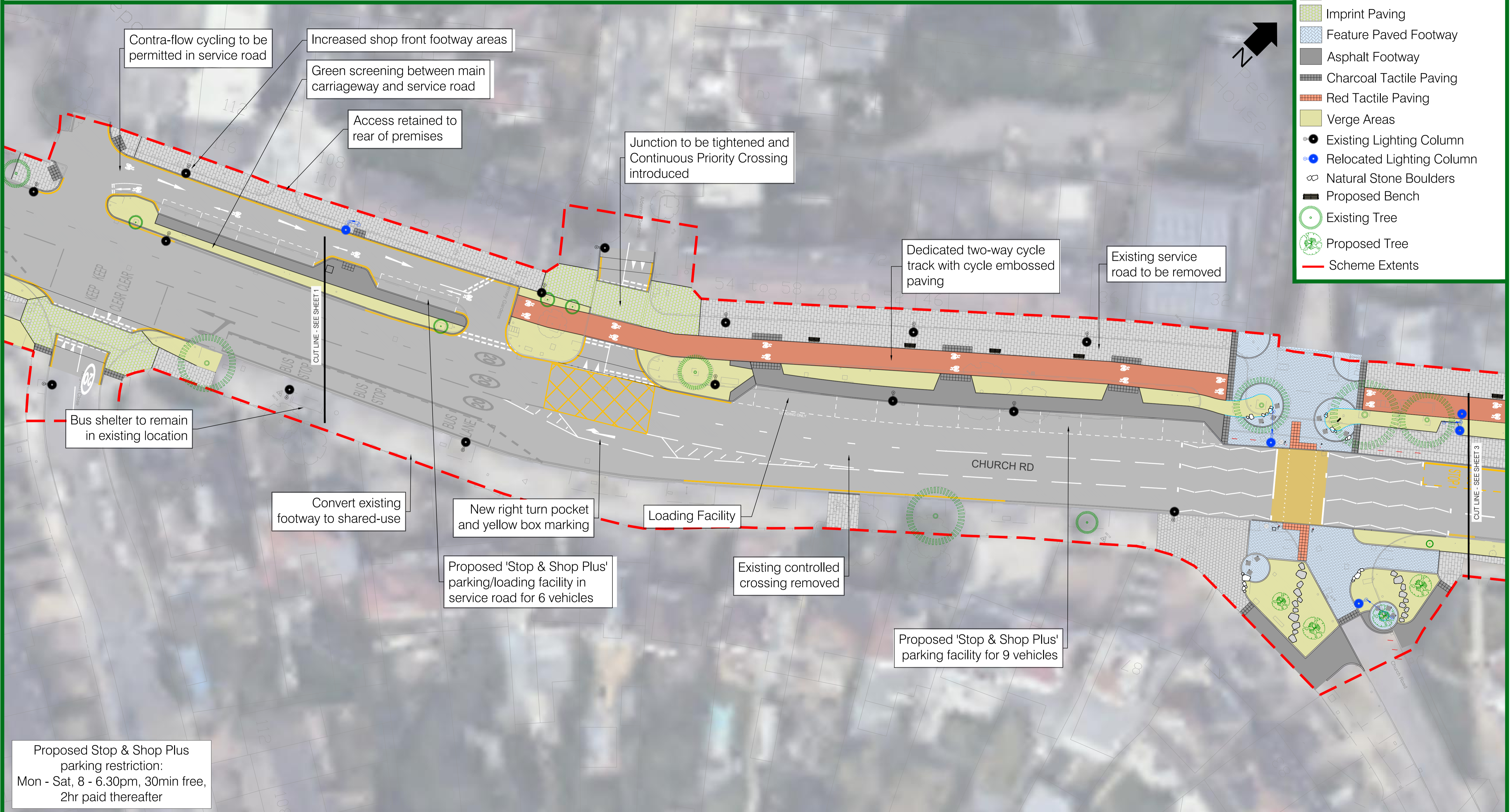

Proposed Stop & Shop Plus parking restriction:
 Mon - Sat, 8 - 6.30pm, 30min free, 2hr paid thereafter

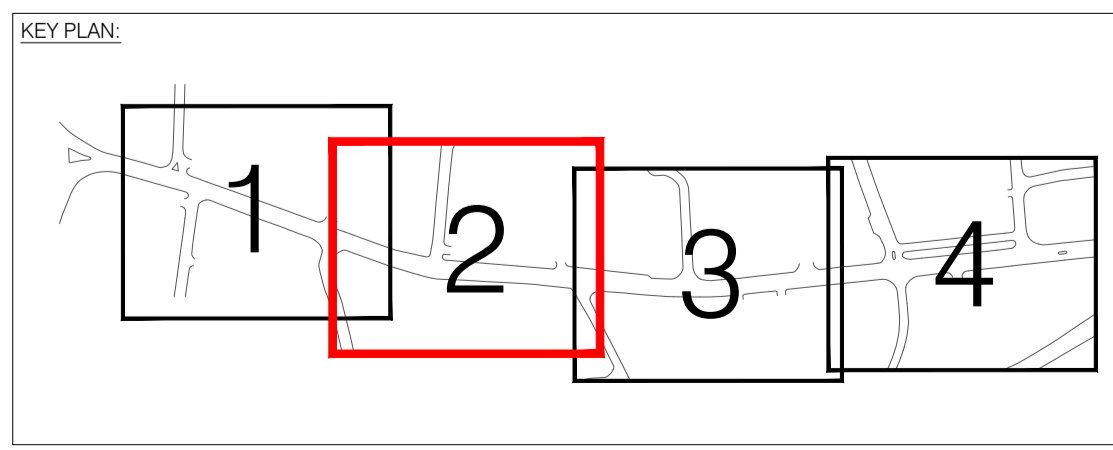

VISIONS FOR NORTHOLT
 MANDEVILLE ROAD IMPROVEMENTS

PROJECT CENTRE
Ealing
www.ealing.gov.uk

GENERAL ARRANGEMENT PLAN

4/CONS-0100-03-R4

- LEGEND
- Asphalt Carriageway
 - Asphalt Carriageway (Coloured)
 - Red Asphalt Cycle Track
 - Flag Paved Footway
 - Imprint Paving
 - Feature Paved Footway
 - Asphalt Footway
 - Charcoal Tactile Paving
 - Red Tactile Paving
 - Verge Areas
 - Existing Lighting Column
 - Relocated Lighting Column
 - Natural Stone Boulders
 - Proposed Bench
 - Existing Tree
 - Proposed Tree
 - Scheme Extents

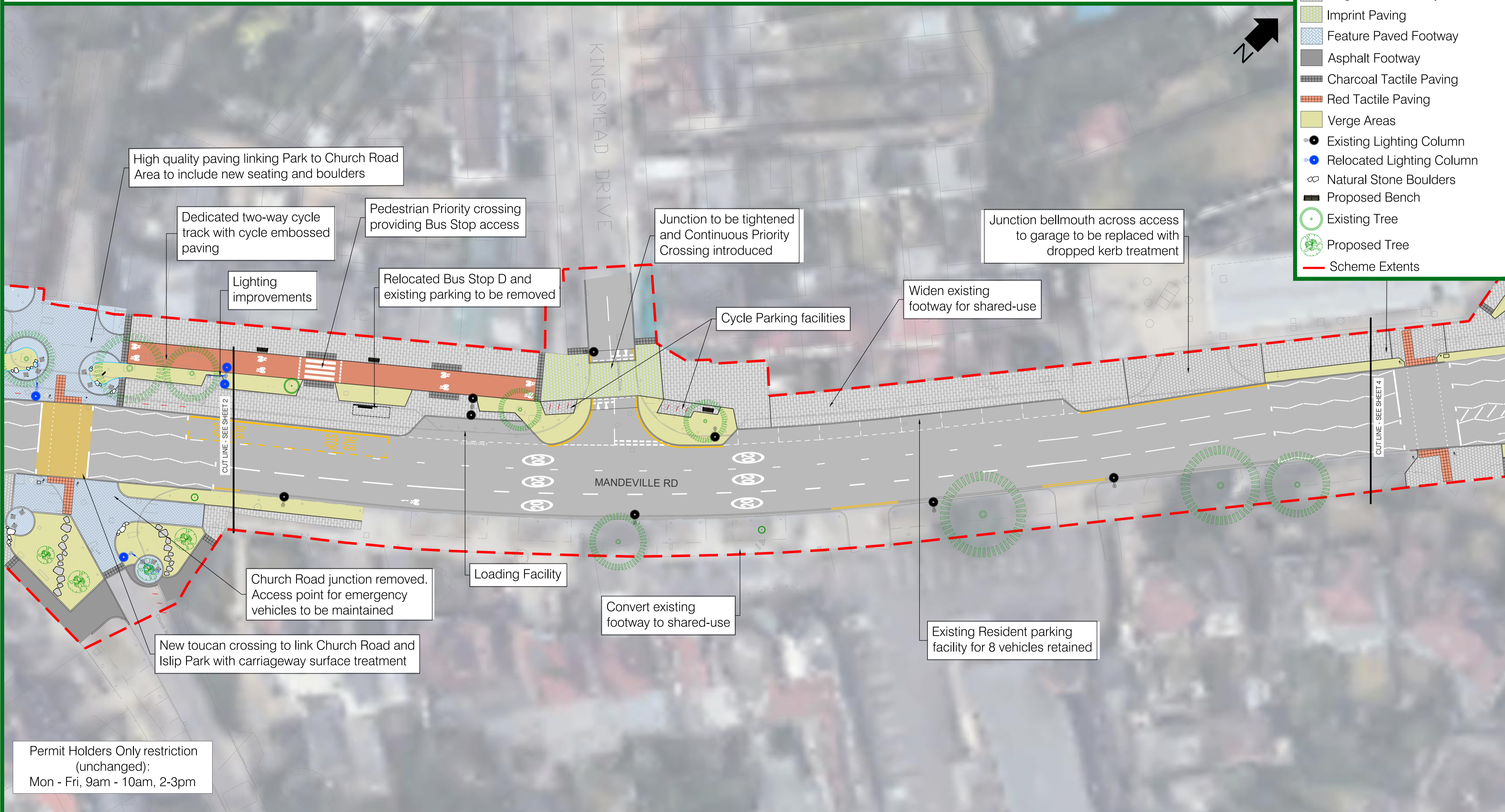

Permit Holders Only restriction
(unchanged):
Mon - Fri, 9am - 10am, 2-3pm

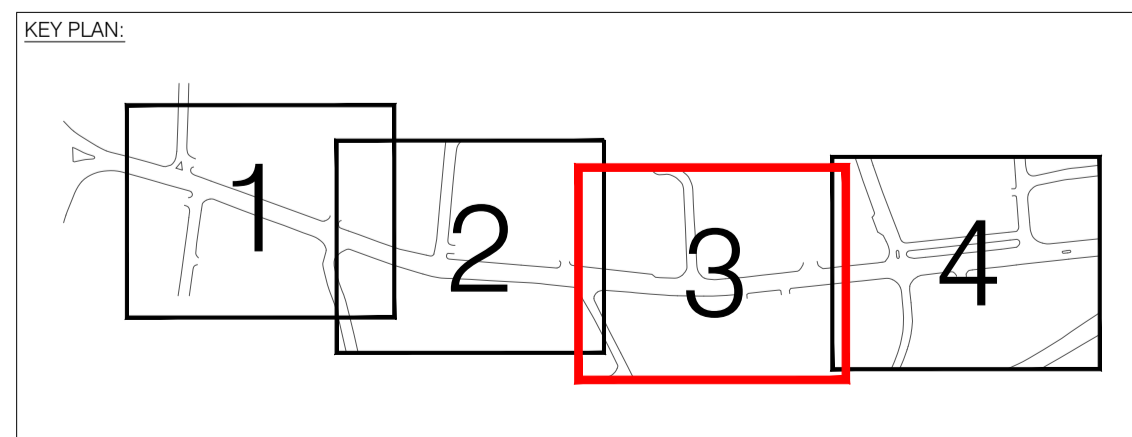

VISIONS FOR NORTHOLT
MANDEVILLE ROAD IMPROVEMENTS

PROJECT CENTRE



GENERAL ARRANGEMENT PLAN

4/CONS-0100-04-R4

- LEGEND
- Asphalt Carriageway
 - Asphalt Carriageway (Coloured)
 - Red Asphalt Cycle Track
 - Flag Paved Footway
 - Imprint Paving
 - Feature Paved Footway
 - Asphalt Footway
 - Charcoal Tactile Paving
 - Red Tactile Paving
 - Verge Areas
 - Existing Lighting Column
 - Relocated Lighting Column
 - Natural Stone Boulders
 - Proposed Bench
 - Existing Tree
 - Proposed Tree
 - Scheme Extents

Proposed Stop & Shop Plus parking restriction:
Mon - Sat, 8 - 6.30pm, 30min free, 2hr paid thereafter

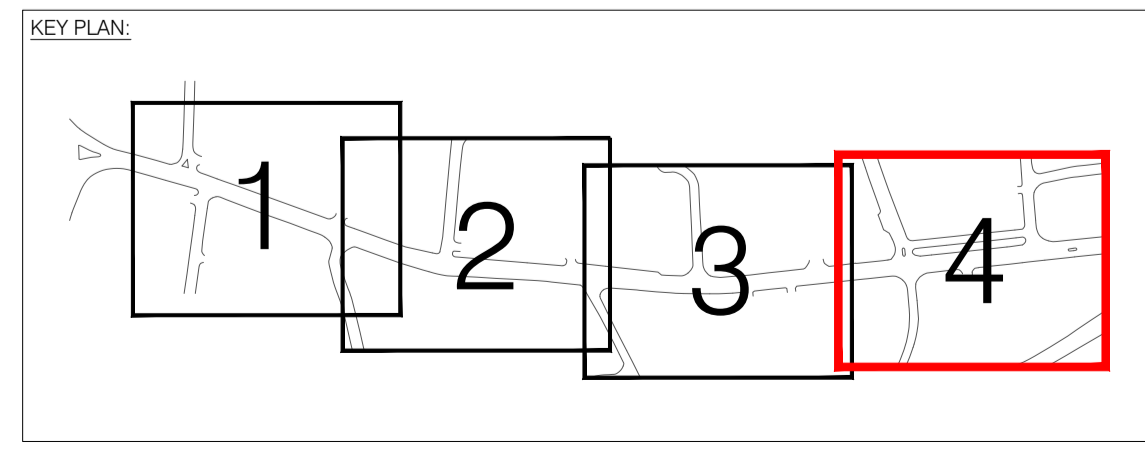
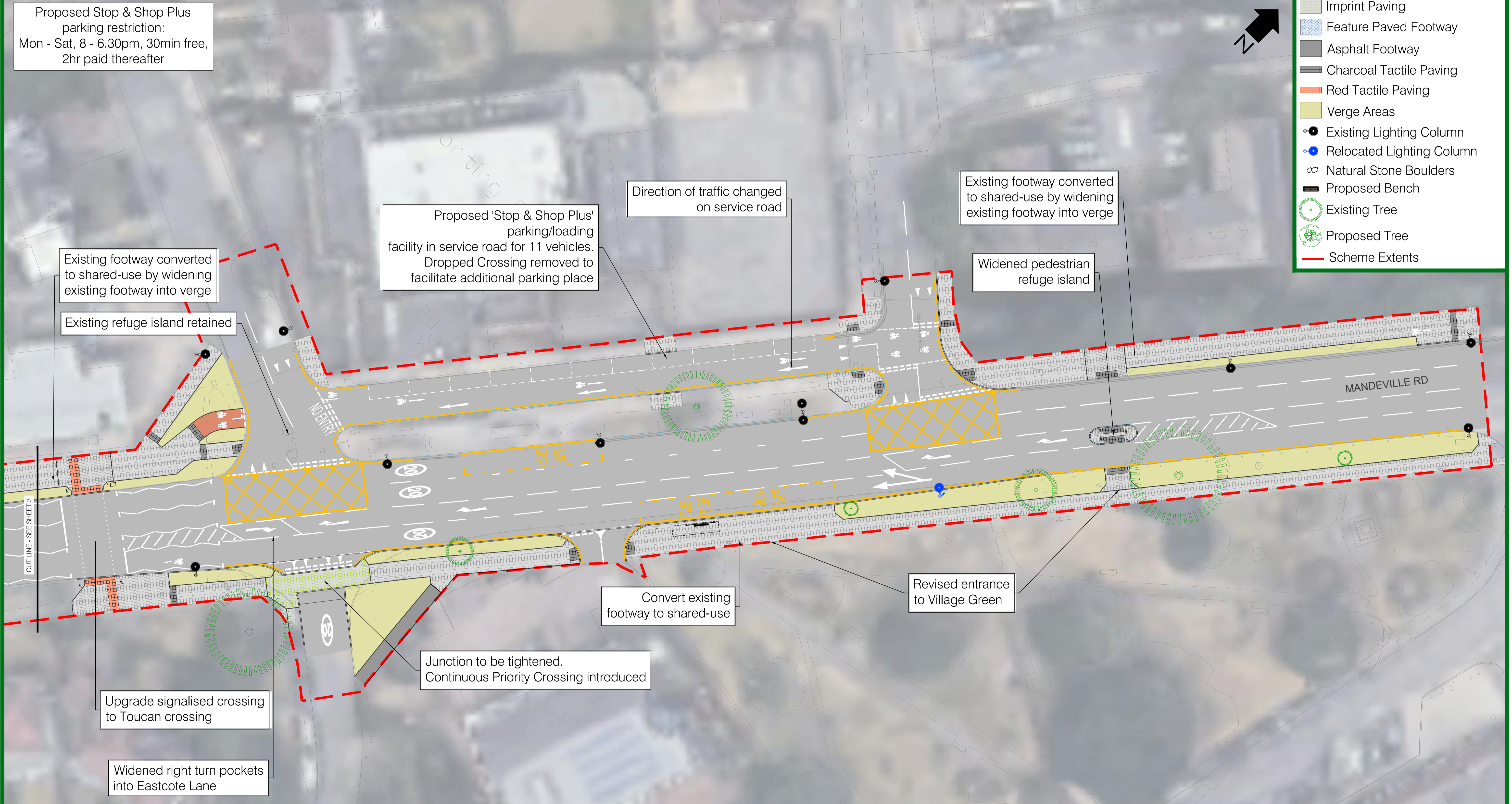

VISIONS FOR NORTHOLT
MANDEVILLE ROAD IMPROVEMENTS

PROJECT CENTRE

